

德瑞特化工程 全區防水施工圖補充說明

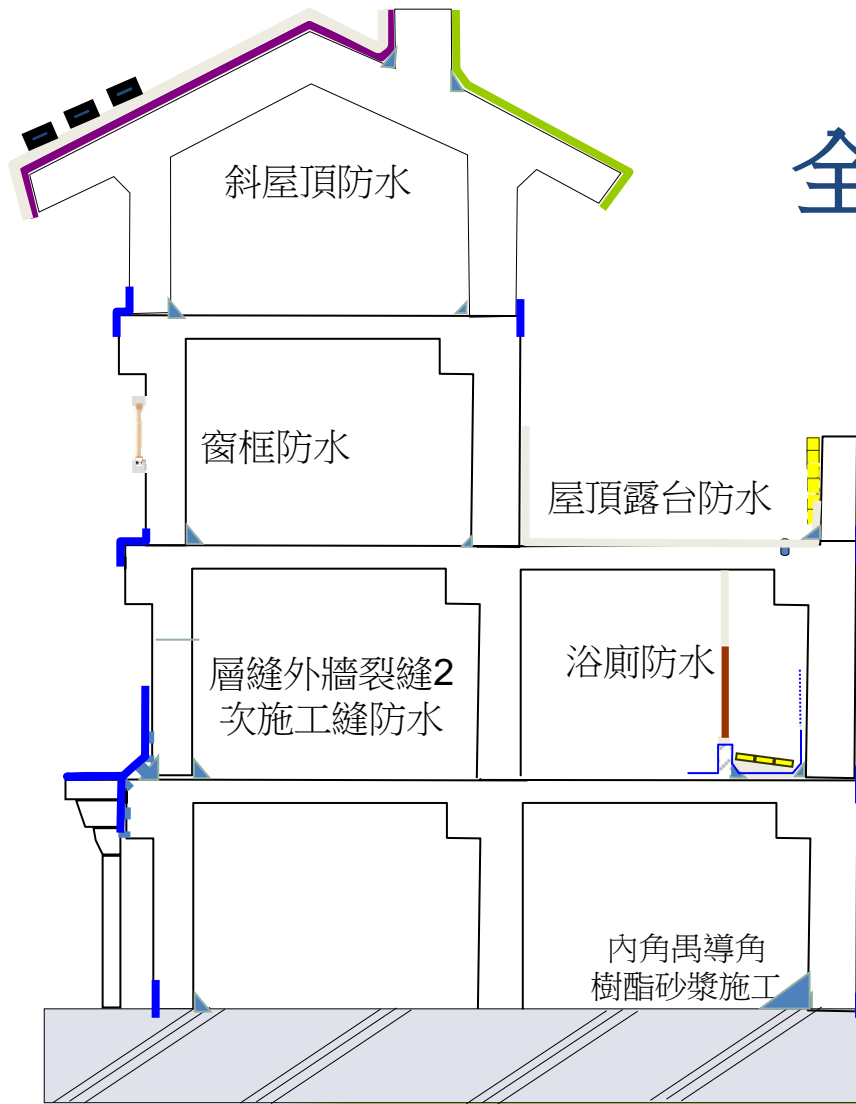

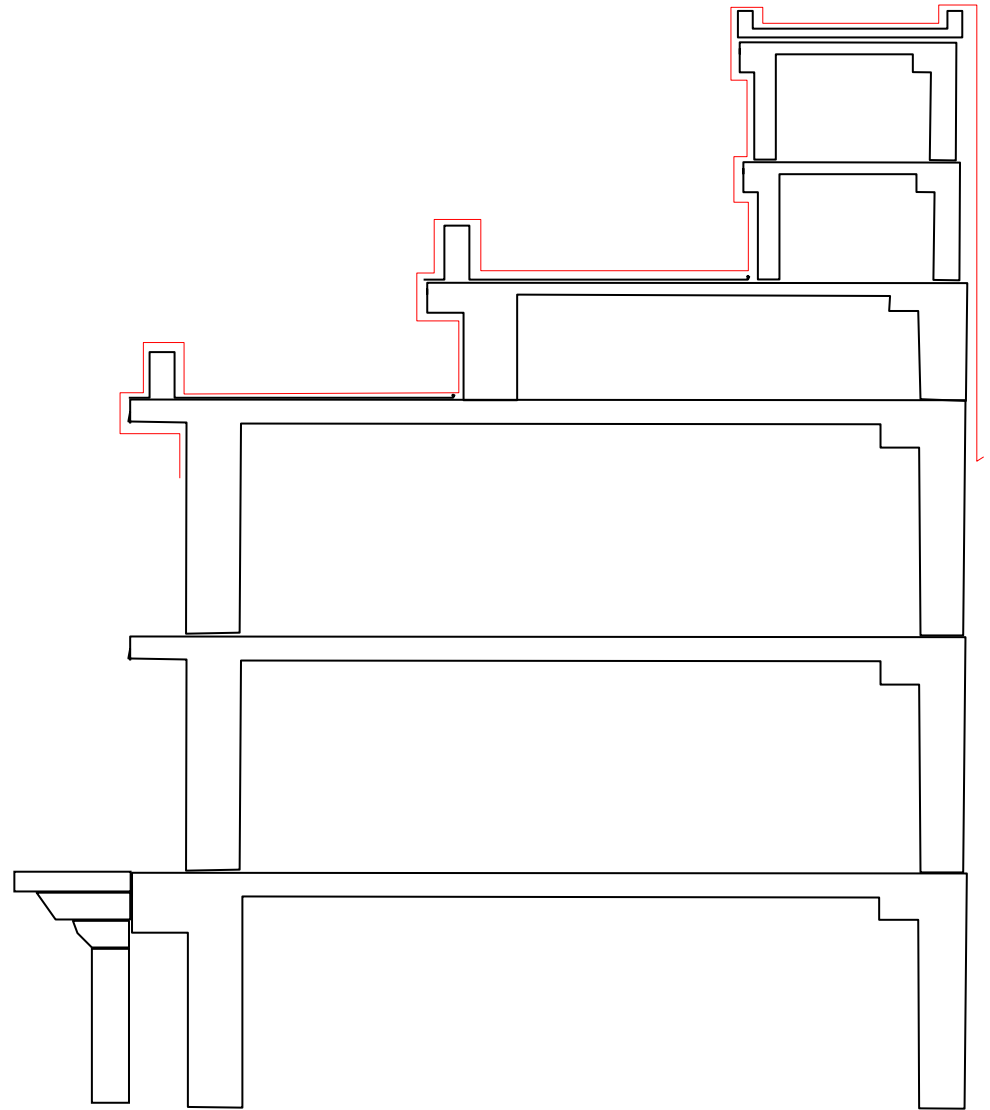



屋頂防水工程保固施工範圍

配合現有建築架構提供有效及經濟工法並檢討，採用複合性防水工法有效抑止外露樑、女兒牆、突一、燈光計劃、管線、窗、落水頭、集水消防、管道間等各式層縫滲水。其間涵蓋大量工程協調。

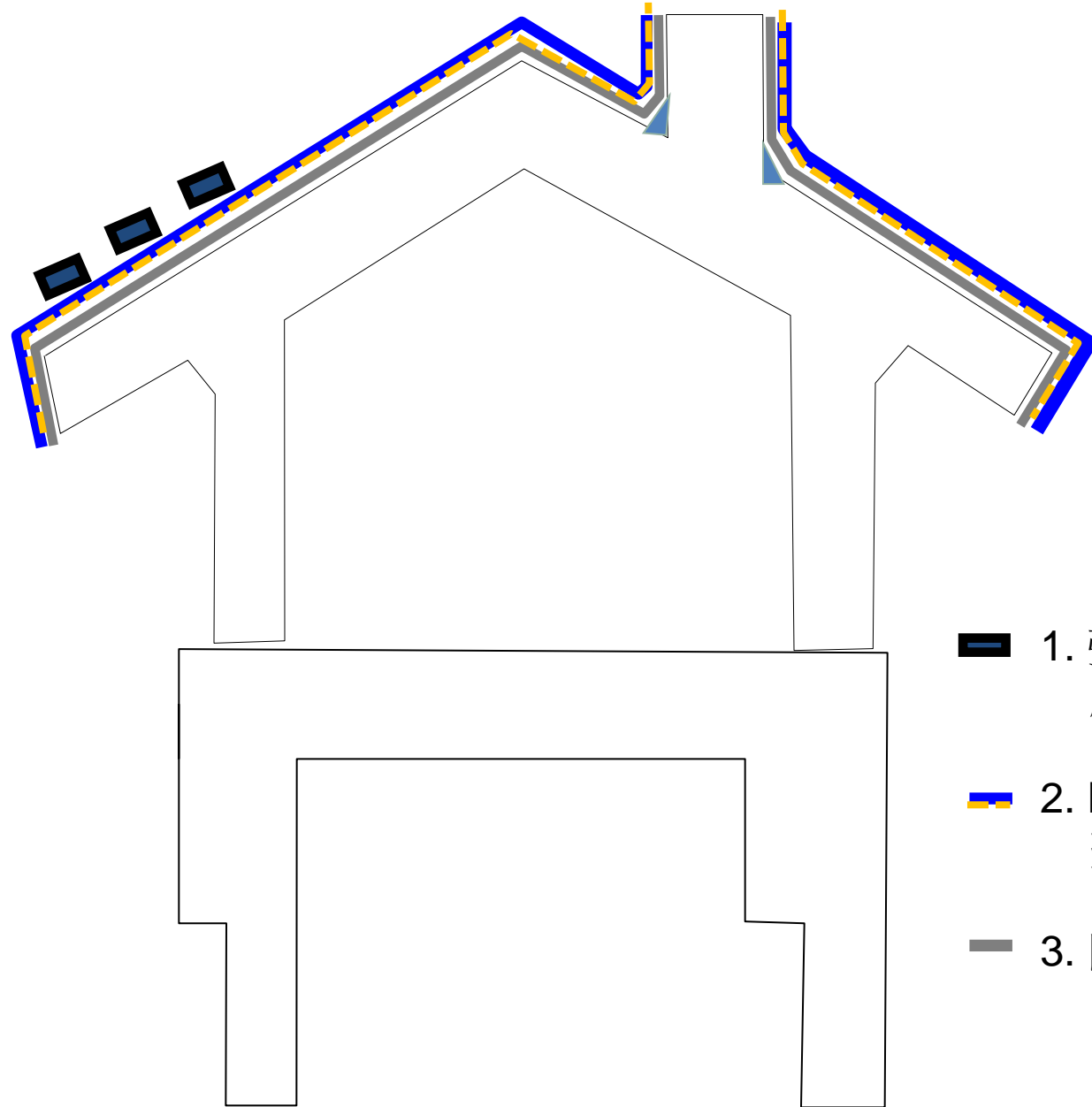

斜屋頂防水施工圖



-  1. 彈泥施塗膠條上，鐵釘部份矽利康披覆簷條釘施作
-  2. BC600複合防水材，一底二塗聚酯抗裂網(Polyester)施工
-  3. 固泥牆防水砂漿粉刷層施工

屋頂立面牆防水工程

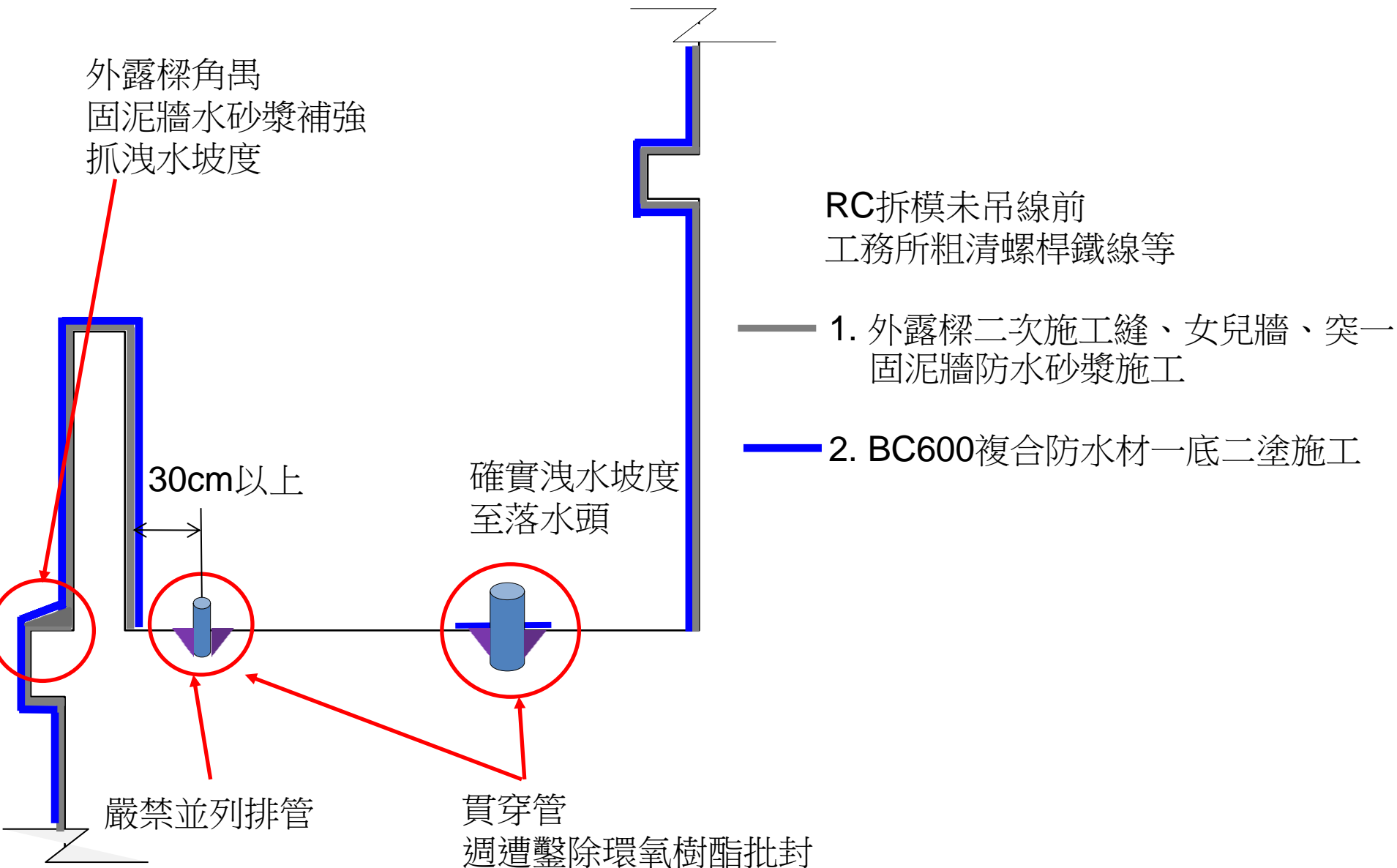

屋頂/露台/陽台平台防水工程(二) 德瑞特化 工程有限公司

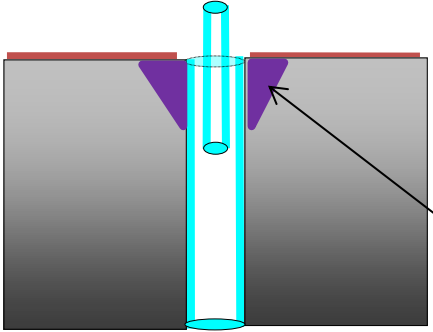

避免水電套管震動
管邊破損開裂造成滲漏
落水頭周遭鑿V槽補強
結構型環氧樹脂
澆注批補

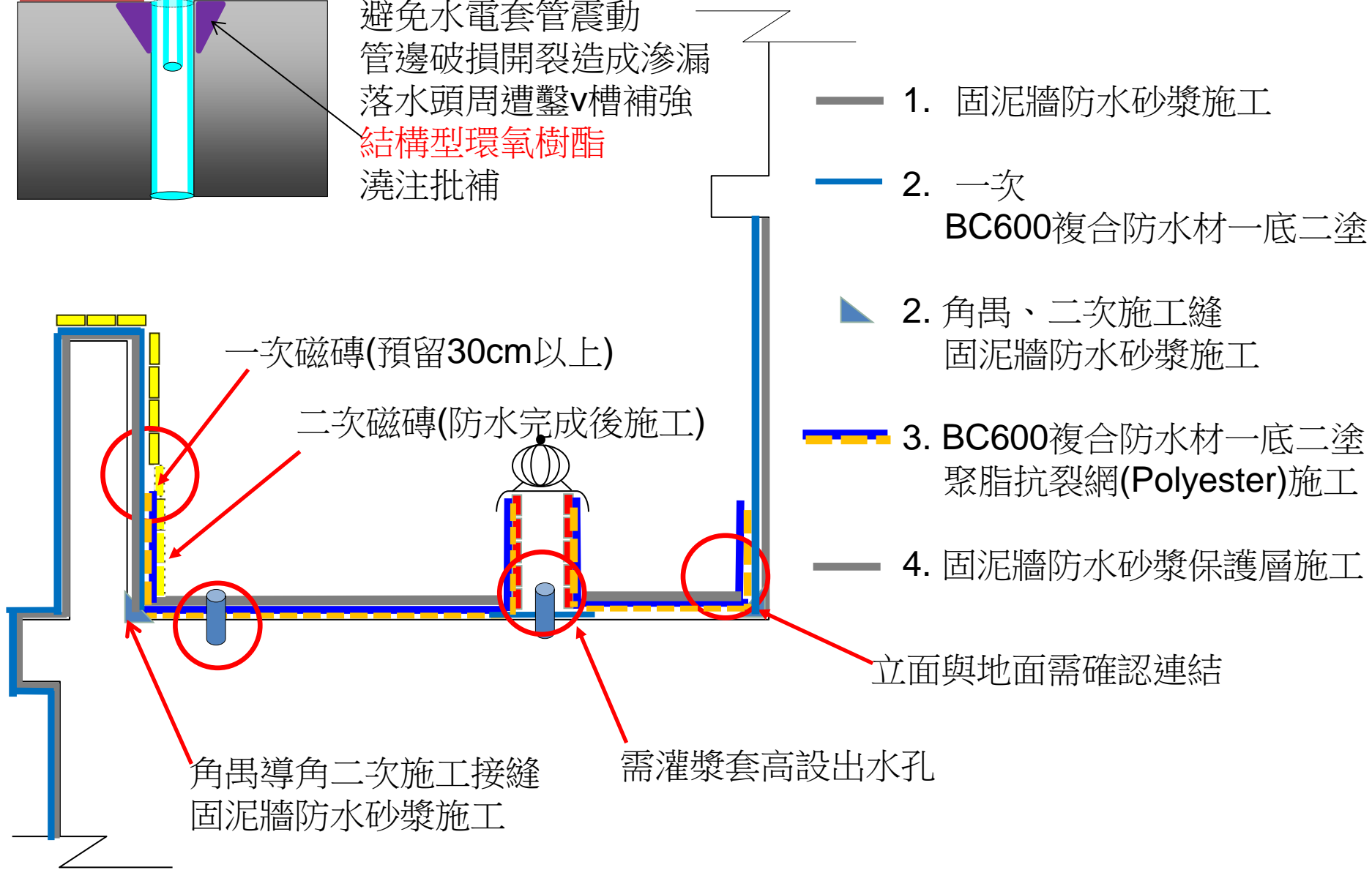

- 1. 固泥牆防水砂漿施工
- 2. 一次
BC600複合防水材一底二塗
- 2. 角隅、二次施工縫
固泥牆防水砂漿施工
- 3. BC600複合防水材一底二塗
聚脂抗裂網(Polyester)施工
- 4. 固泥牆防水砂漿保護層施工

一次磁磚(預留30cm以上)

二次磁磚(防水完成後施工)





立面與地面需確認連結

角隅導角二次施工接縫
固泥牆防水砂漿施工

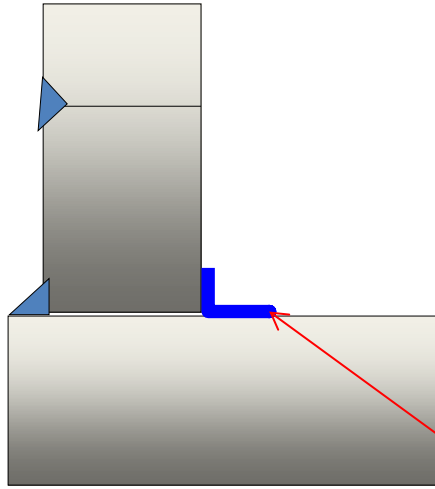
需灌漿套高設出水孔

外牆防水施工圖



-  1. 內牆層縫、二次施工縫、導角
BC600複合防水材一底二塗施工
-  2. 角隅二次施工縫
固泥牆防水砂漿施工
-  3. 外牆固泥牆防水砂漿粉刷層施工
-  4. BC600複合防水材一底二塗
聚脂抗裂網(Polyester)施工
-  5. BC600複合防水材一底二塗施工

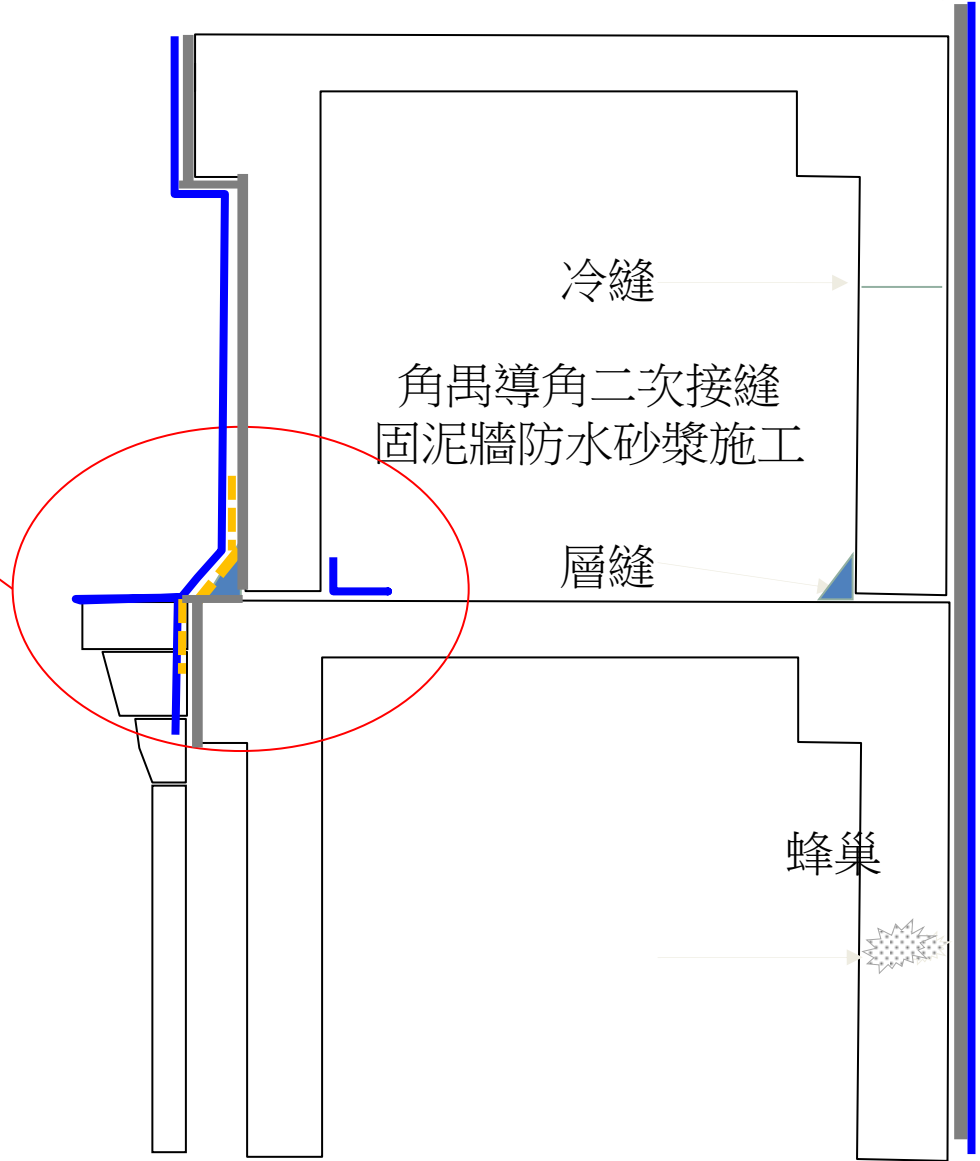



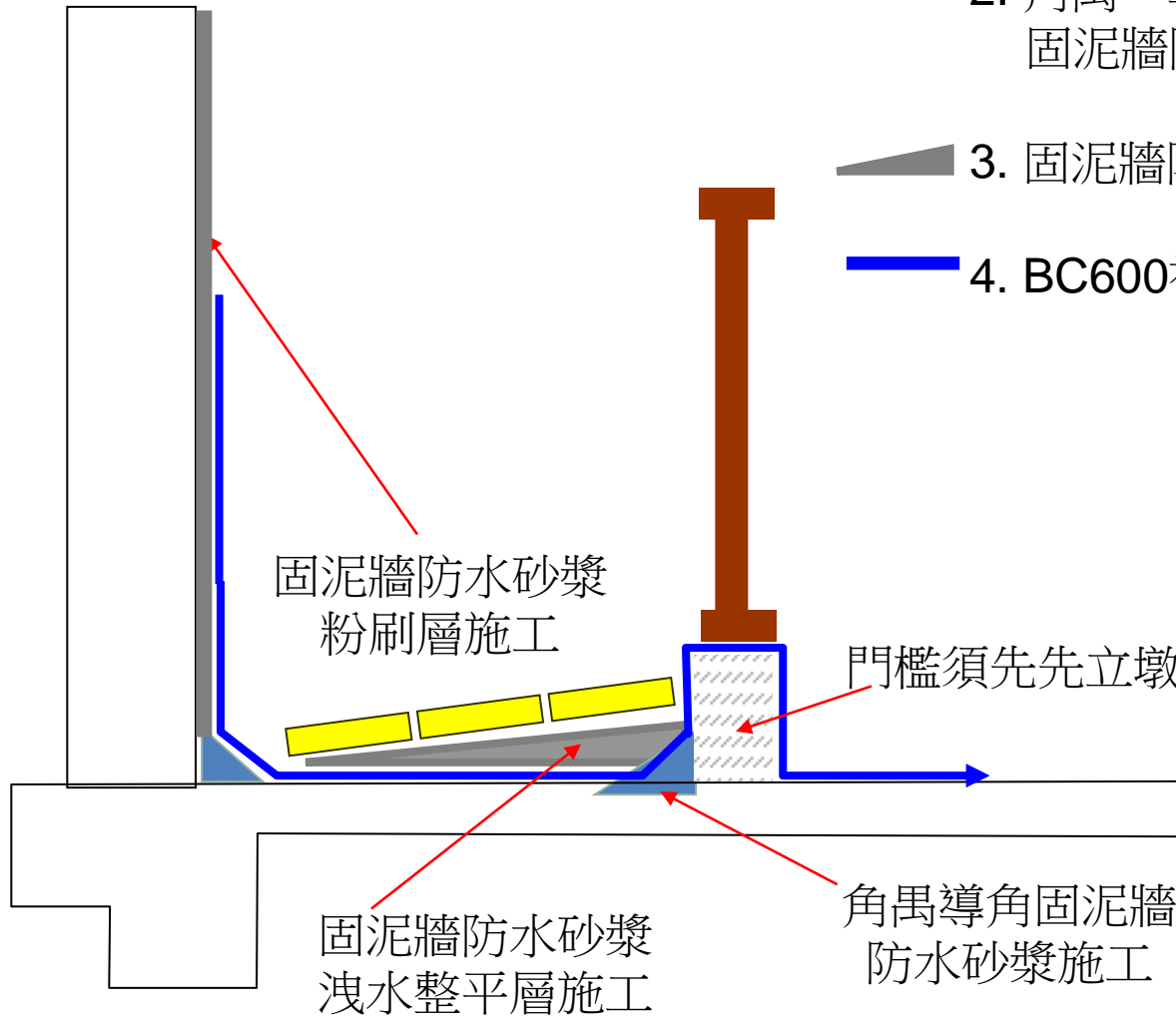

浴廁防水施工圖

- 1. 固泥牆防水砂漿粉刷層施工
- ▲ 2. 角隅、導角
固泥牆防水砂漿施工
- ▲ 3. 固泥牆防水砂漿洩水整平層施工
- 4. BC600複合防水材，一底二塗施工

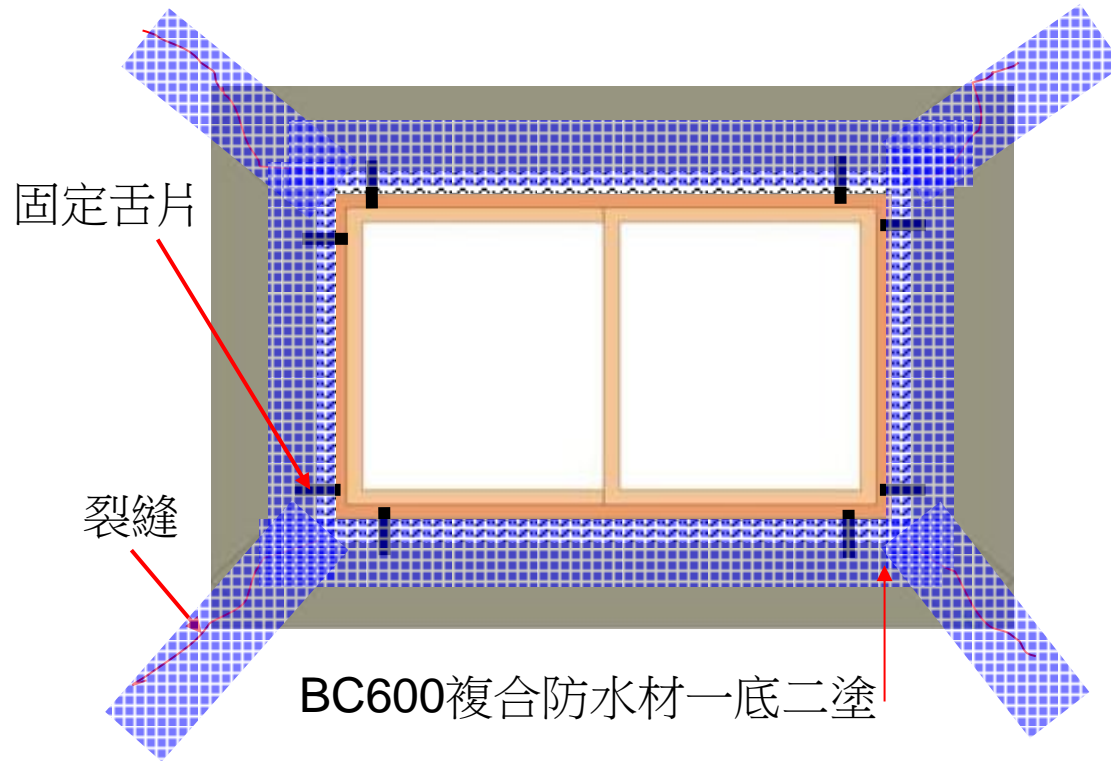

窗框防水施工圖



-   1. DC600複合防水材
聚脂抗裂網(Polyester)施工
-  2. 固泥牆防水砂漿塞縫施工
-  3. DC600複合防水材施工

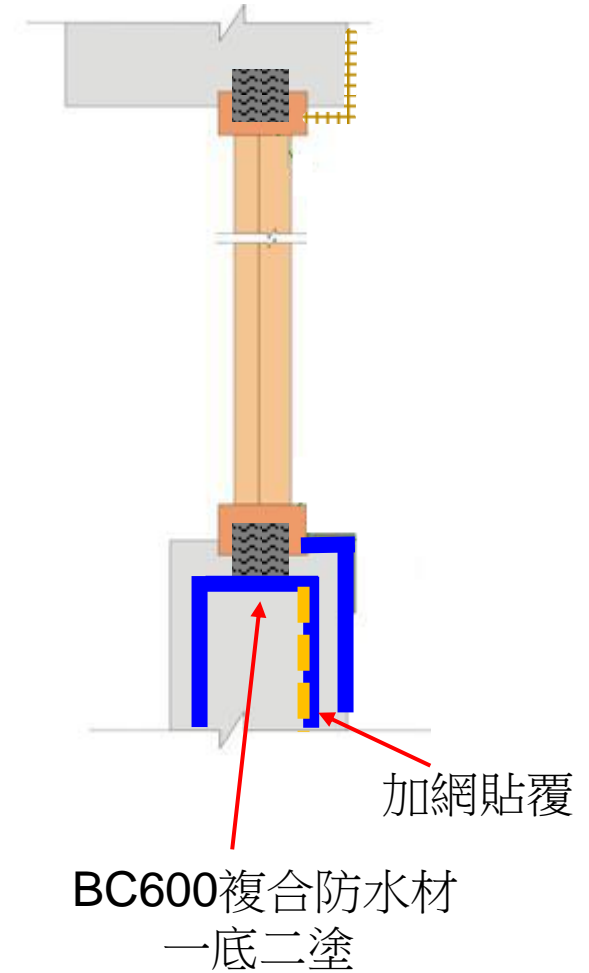

明挖地下室外牆防水施工圖

德瑞特化
工程有限公司

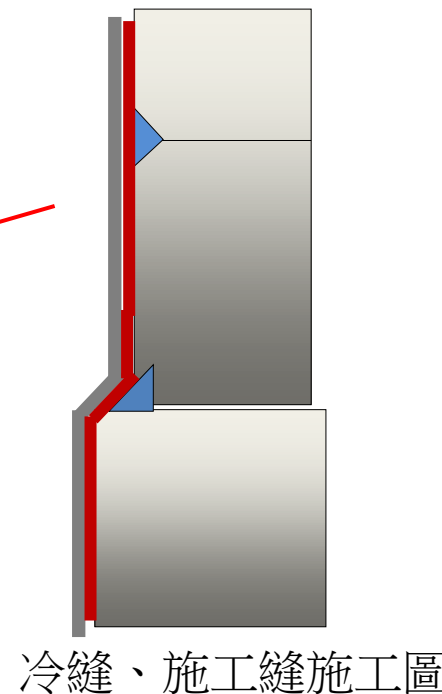
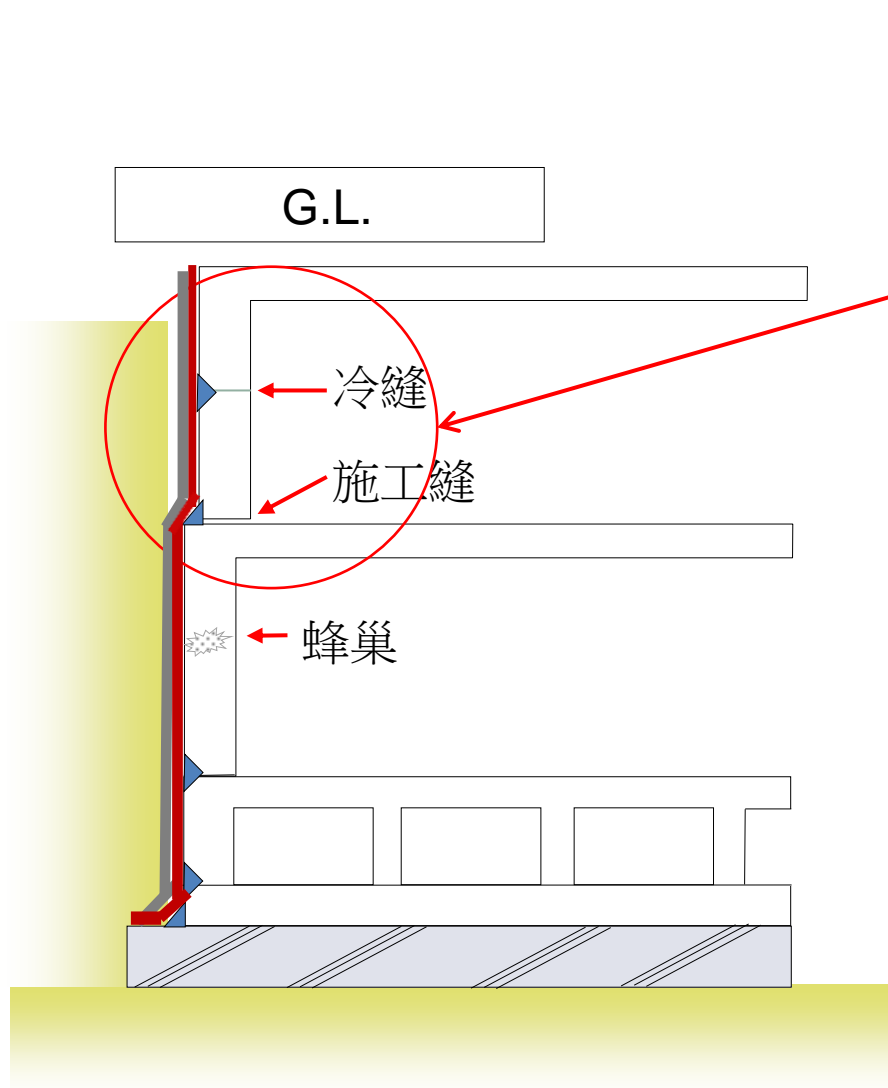

- ▲ 1. 二次施工縫敲除
固泥牆防水砂漿缺陷處修繕
- 2. DAVCO K11 MATRYX
水泥結晶防水材一底二塗施工
- 3. 固泥牆防水砂漿粉刷施工

地下室連續壁、單片牆防水施工圖

G.L.

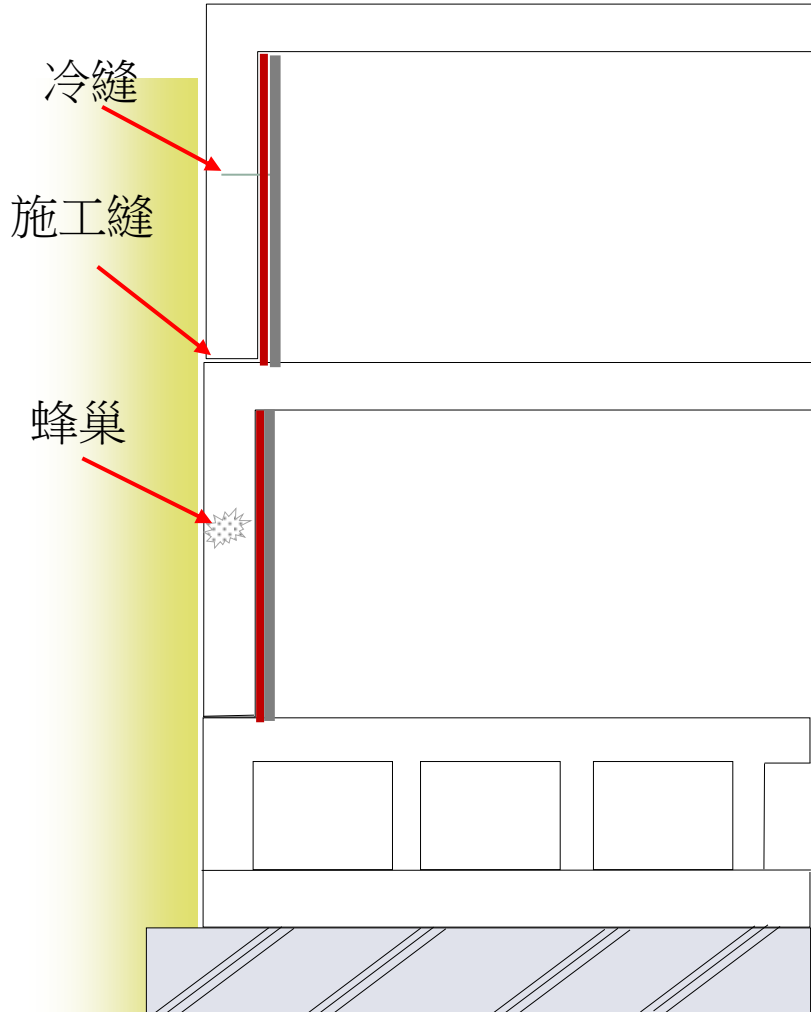

- 1. DAVCO K11 MATRYX
水泥結晶防水材料一底二塗施工
- 2. 固泥牆防水砂漿粉刷施工

屋頂立面牆防水補充說明(一)

1. RC拆模未吊線前；工務所粗清螺桿鐵線後 施塗防水材一塗 女兒牆窗開口彈泥施塗 燈光計劃、消防管線、管線出口、素地處理，環氧樹脂批封封塞。



2. 外露樑、女兒牆、突1外牆，吊線打石修邊。(防水小包需隨後再次修補)。
3. 固泥牆防水砂漿素面粉刷完成後，二次施塗防水材一塗。



屋頂立面牆防水補充說明(二)

4. 外露樑、女兒牆、突1外牆，二次彈泥施塗，但需確認固泥牆防水砂漿初凝濕度，面乾再施塗。施塗面外牆需延伸到底，所有施塗過程需注意考量未來完成面之高層、面層，以確保磁磚貼附面之平整。



5. 外牆磁磚貼附：防水小包須配合磁磚貼附時，貼面不齊，復修除之防水修補。
女兒牆及管道間貼附：下方需預留**30cm**以上之高度，以利二次地坪防水之接續施工。
突一側牆，水錶位儘可能預留不貼磁磚，以利水電修改及下方預留**30cm**以利二次接續。



屋頂立面牆防水補充說明(三)

6. 當一次防水及磁磚完成後，必須針對管線管邊進行封塞，電管類·電線出線如無誤，即可使用一般發泡填縫劑填補，水電消防幹管週邊，亦先使用填縫劑修補，面層再施打矽利康與金屬面結合。



屋頂平台露台防水補充說明

德瑞特化
工程有限公司

1. 使照取得後工地素地粗清，針對屋頂地坪、砂礫、鋼筋、木板、鐵釘、混凝土突出物等清除，防水包商進行細清及屋頂防水工程。
2. 素面整理：檢視所有凹面或蜂巢劣質混凝土，用固泥牆防水砂漿修補。



屋頂平台露台防水補充說明

3. 打底：將壓克力彈性材添加5%—10%水(視天氣濕度)稀釋，全面施塗，以利防水接著。
4. 施塗：待一打底初凝風乾後，即可進行防水施塗，前後兩次，而施塗方向不同，較能辨別層次，而落水頭皆需加網，以防塑膠管之銳角傷害防水，而所施塗面皆需加高與一次施塗面交接。
5. 面塗：待二層防水完成後，可施作橡化瀝青面塗施塗面以地坪面為主，立面不施塗（油性面磁磚無法貼合）相同橫直向兩道施塗。



6. 試水：防水完成後即可，進行5～7天之儲水測漏，其間避免人員上屋頂施工。

屋頂平台露台防水補充說明

7. 修補在一次防水完成後，須再次檢驗所有施作面未來之接續，如防火門、管線週邊、落水頭、其他施工廠商之破壞部份進行修補。



8. 養生防護：

- ①瓷磚：貼覆面之不整，及倒角突出，銳角之收邊，皆需再次修補。
- ②管線：新配管、管道間頂蓋施工前之積水、空管封塞、燈光計劃之燈座、集水管架、皆需再次修補。
- ③地磚：
 - ①吊料：吊料屋頂時，地面須鋪設墊地，以防產物破壞
 - ②拌合：翻土機、沙鏟等拌合作業，損及防水層應避免部份
 - ③工作人員：不應使用釘鞋，可改為膠製平底鞋施作。
- ⑤反潮：如日曬或雨淋試水後，因有無法目視之細縫針孔滲水，造成反潮防水鼓漲，則需再次切除防水，擴大修補。

屋頂平台露台漏水檢討現場施工協調

1. 外露樑及女兒牆、突一牆層縫滲水。因立面防水未能與地面防水連接，致使 水水經由防水內側溢入層縫，再滲入屋內樑板滲水。

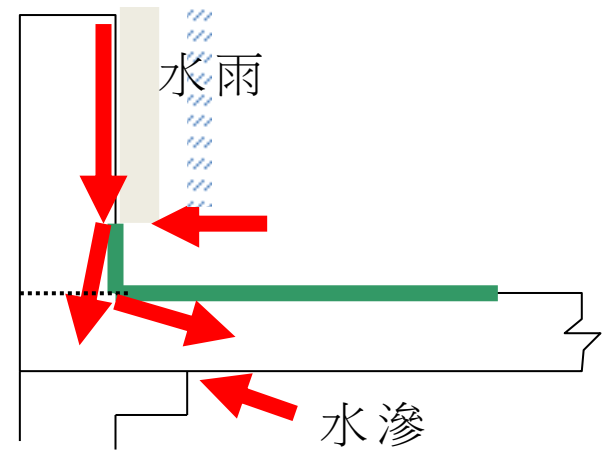

2. 管路、集水管、消防管、燈光計劃管線、落水頭此部份以往常因施工商修改及破管或落水管位置不對、電管出管太低回流，而管週遭之收邊及外露電管亦常滲入。

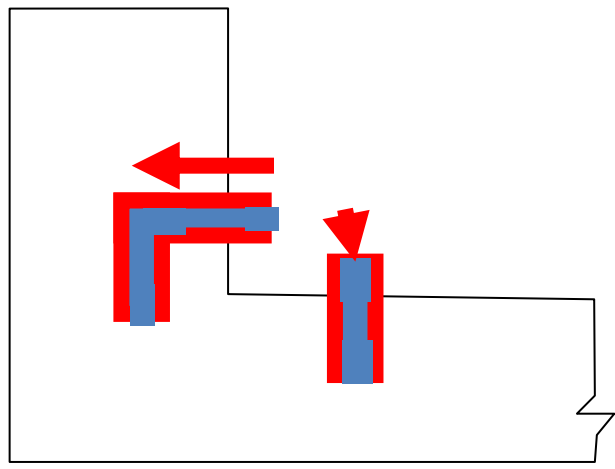
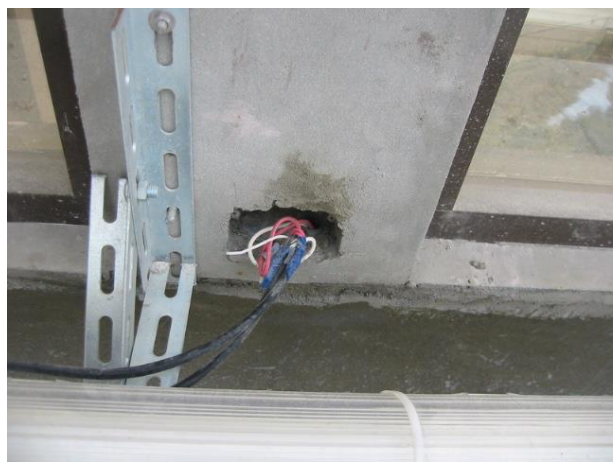

屋頂平台露台漏水檢討現場施工協調

3. 管道間多為砌磚且無牆面防水，亦無圍水 R C 或靠近女兒牆及突一側牆，亦常滲入管道造成各層廁所滲水。



4. 窗開口：女兒牆立窗部份皆需修改組並打釘固定，而塞縫過程亦無飽滿，而滲入防水層造成滲水。



屋頂平台露台漏水檢討現場施工協調

5. 粉刷打底女兒牆及突一牆或外露樑皆為防水之素面，而前後之施作，皆會造成防水結合之漏洞而造成滲水。



6. 吊料搬運造成破孔，落水頭置留於樓板洩水高點放樣錯誤及洩水不足，導致防水層外露，攪拌砂漿刮傷防水...等造成滲水。



SPA水池防水公務所施工協調注意事項 粗清(公務所施工)



板縫凸面儘量磨平修補

所有銳角修補成U型狀



太大之蜂巢需以無收縮水泥修補

SPA水池防水公務所施工協調注意事項

德瑞特化
工程有限公司

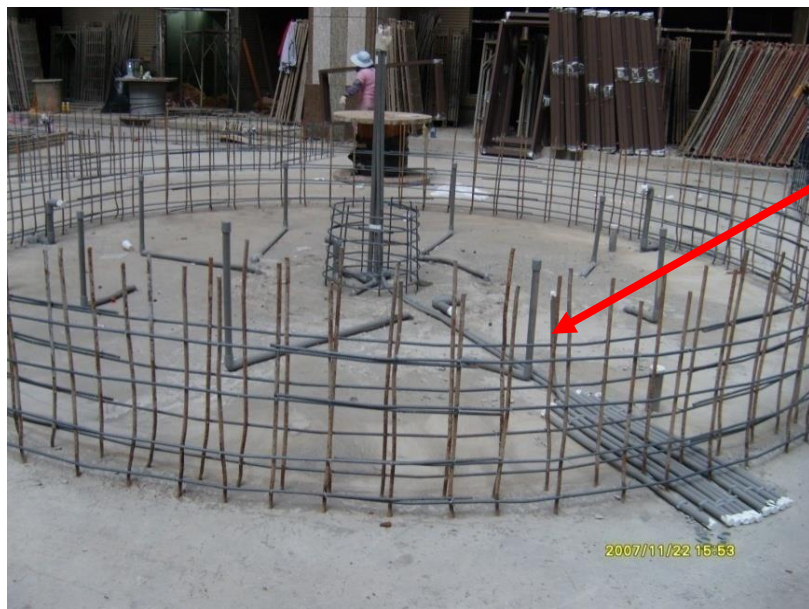

Spa配管廠商需將出入水或排水皆裝錶
塞迴路試水5kg/cm²
直到防水施工完成,
才可洩壓



嚴禁任何管線並列
依靠地面壁體



SPA水池防水公務所施工協調注意事項

德瑞特化
工程有限公司



未來石材或燈飾出入水，
排水，飾板面板，請避免
鎖孔或打鑿作業



防水作業管線需全程試水

所有管線飾材需防水
先施工再裝設



防水施工協調前置工種缺失改善

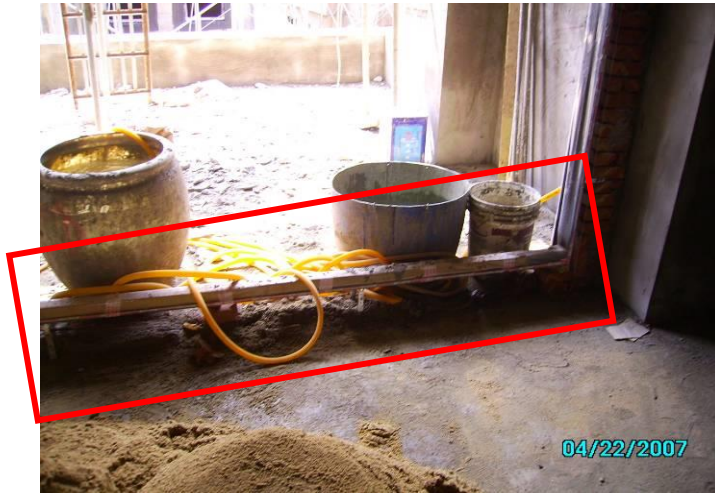

屋頂外露台落地窗坎縫需確實防水施工完畢需有洩水坡度

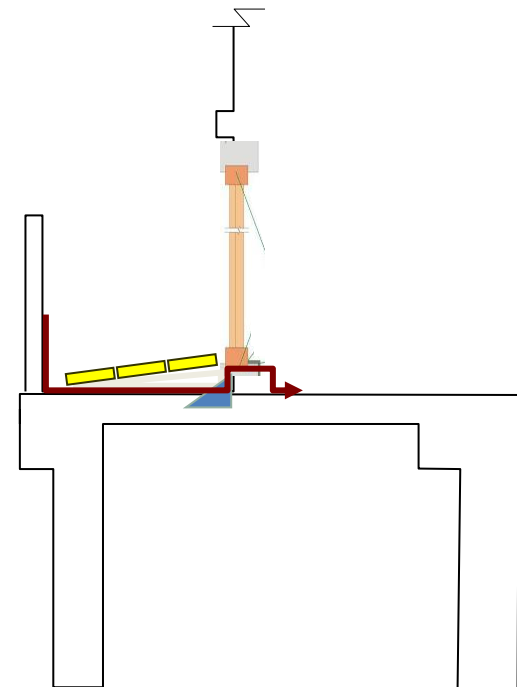
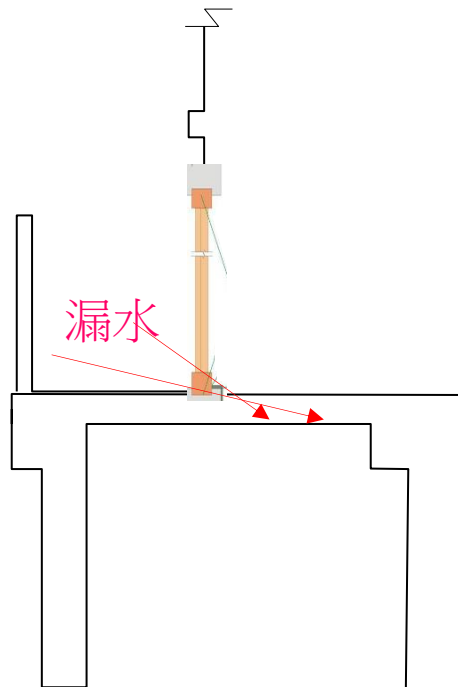

防水施工協調前置工種缺失改善

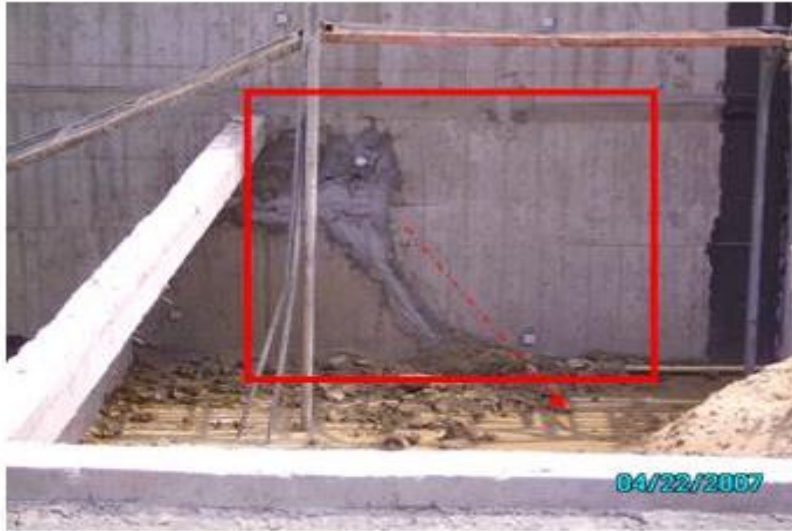

屋頂外露台給水管、電管管線走向BOX須備防水功能及修改管外牆加強防水施工

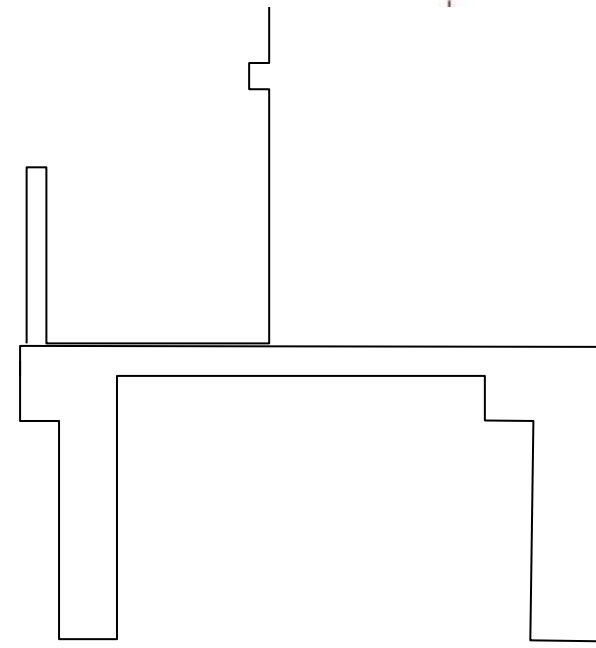
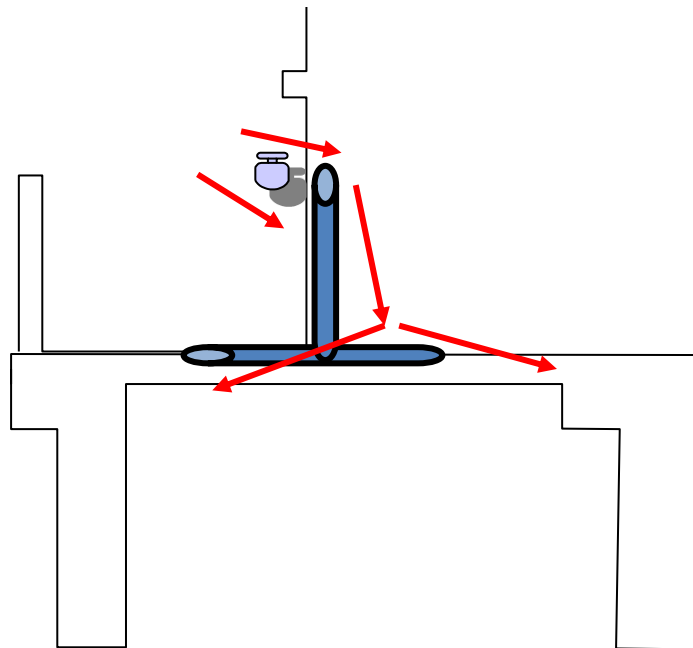

防水施工協調前置工種缺失改善

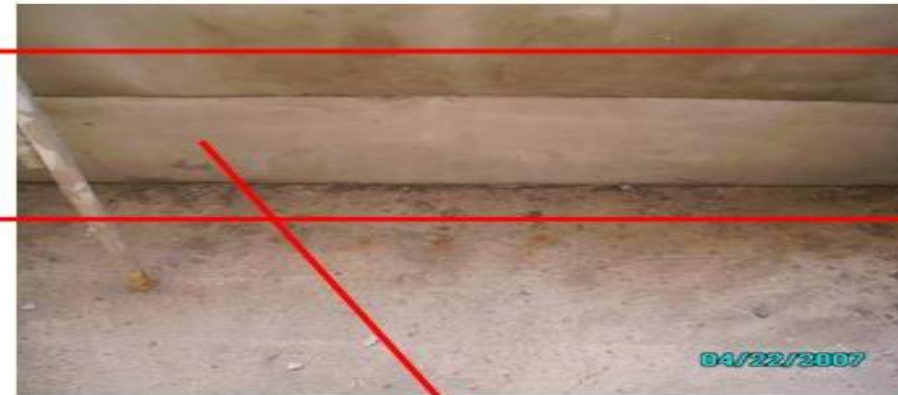

屋頂外露台女兒牆粉刷層，下方必須預留30cm-40cm防水施工範圍，已粉刷到底的部分需敲除。

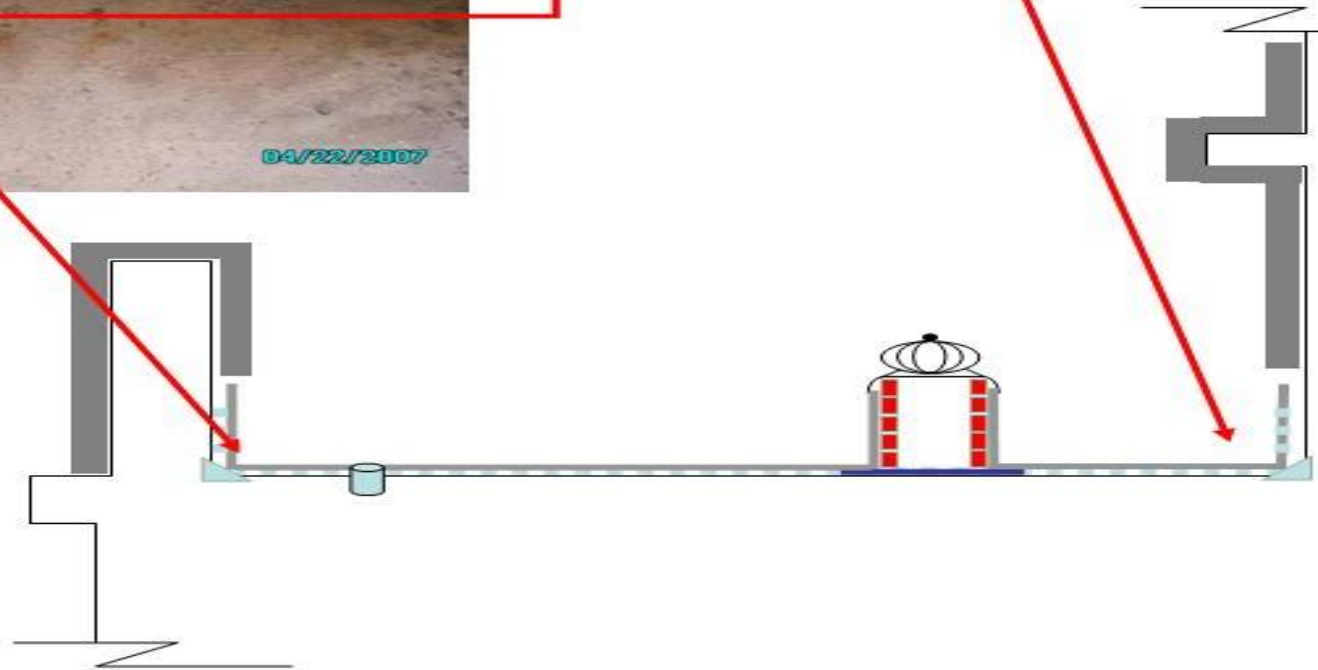

防水施工協調前置工種缺失改善



斜頂全面防水施工

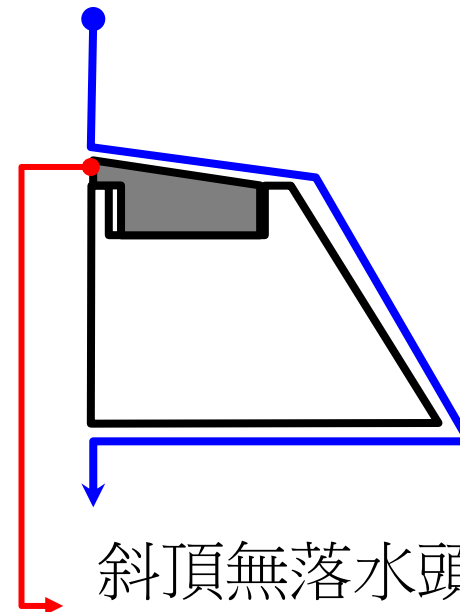
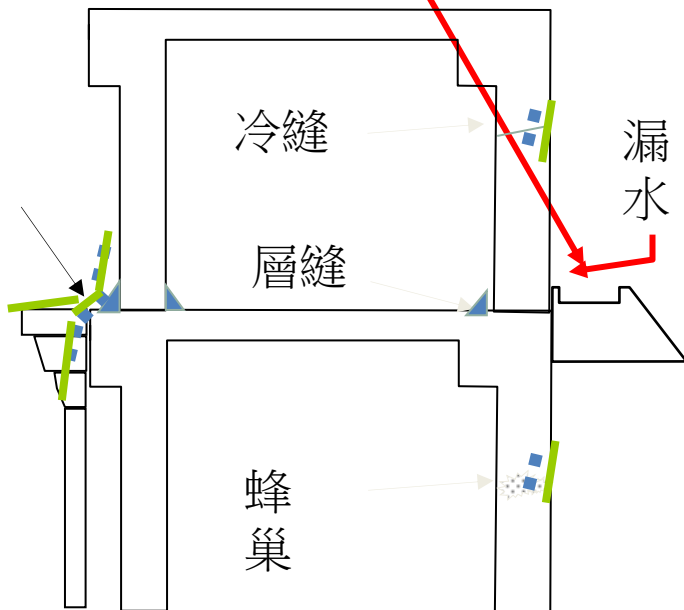

防水施工協調前置工種缺失改善

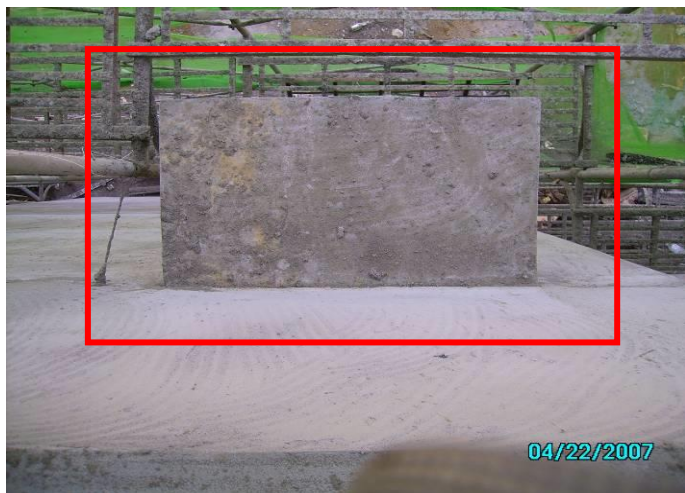

窗框上緣雨遮，施工縫需全面防水施工

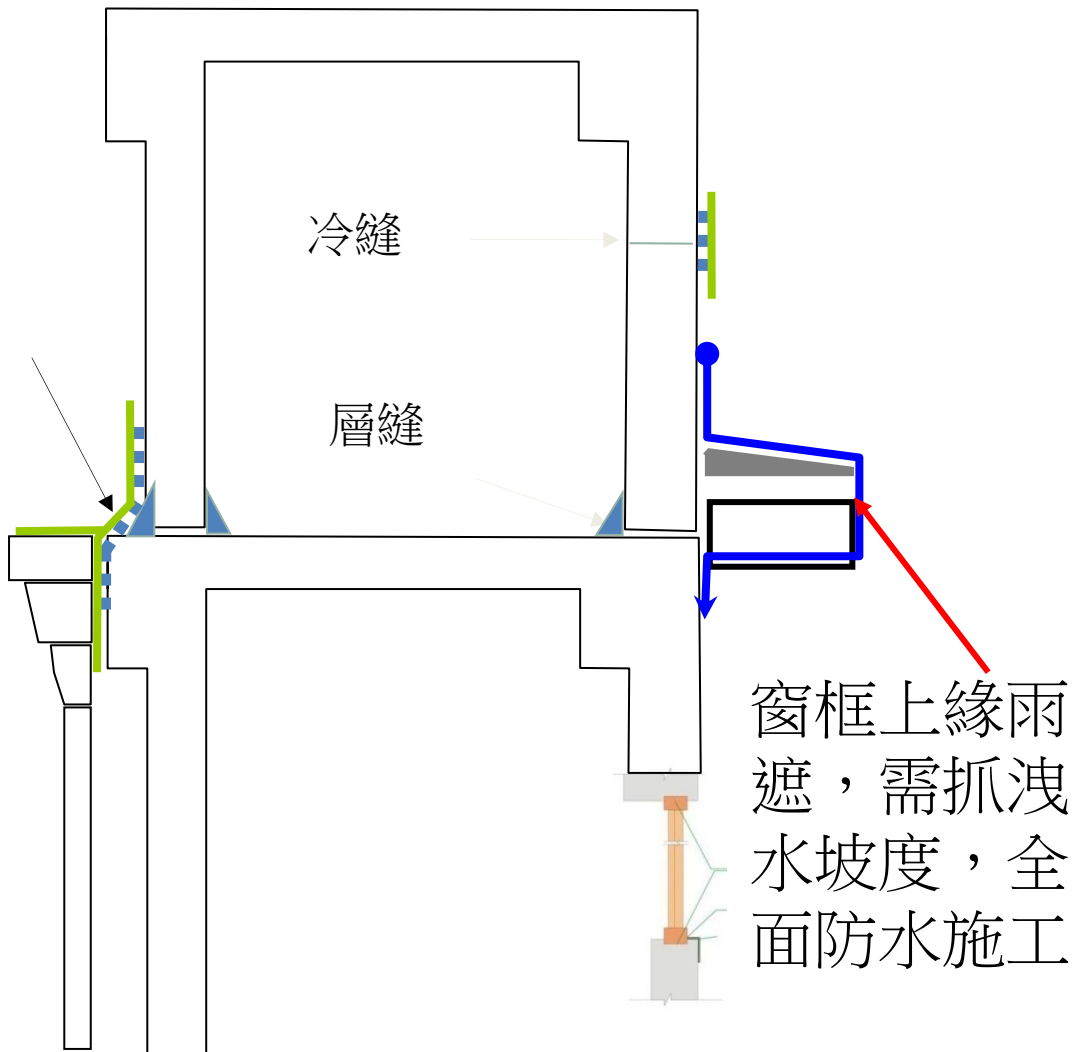

防水施工協調前置工種缺失改善

窗框下緣造型施工縫無法施工
需下緣造型全面防水施工

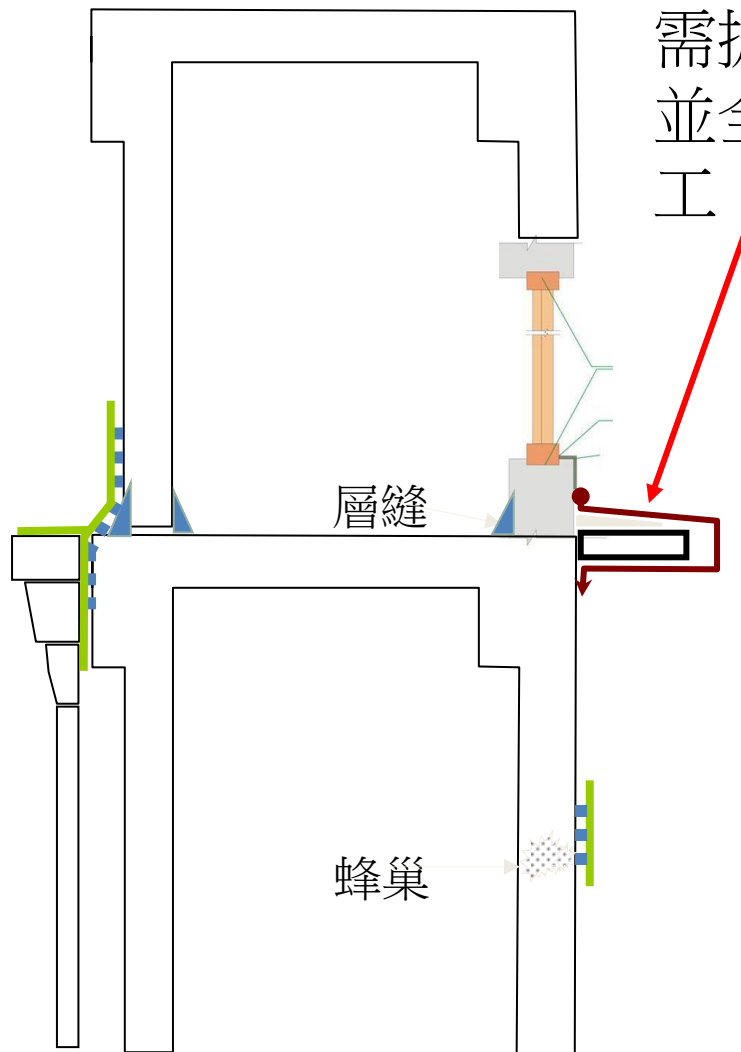
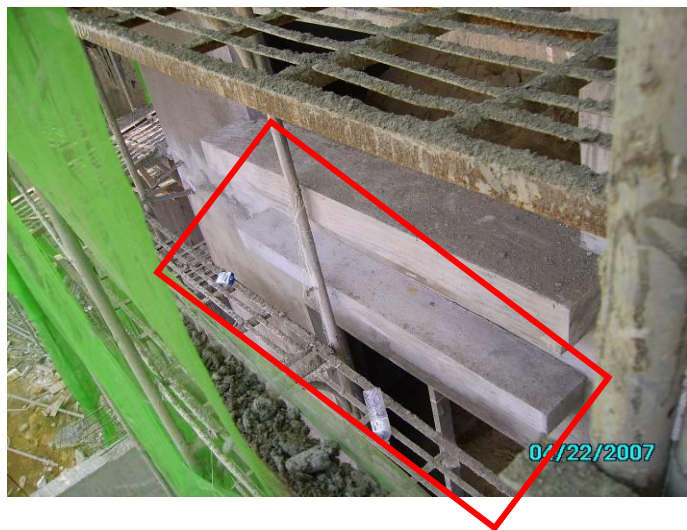

窗框下緣造型，
需抓洩水坡度，
並全面防水施
工

防水施工協調前置工種缺失改善

屋頂外露台女兒牆造型週遭需全面防水施工

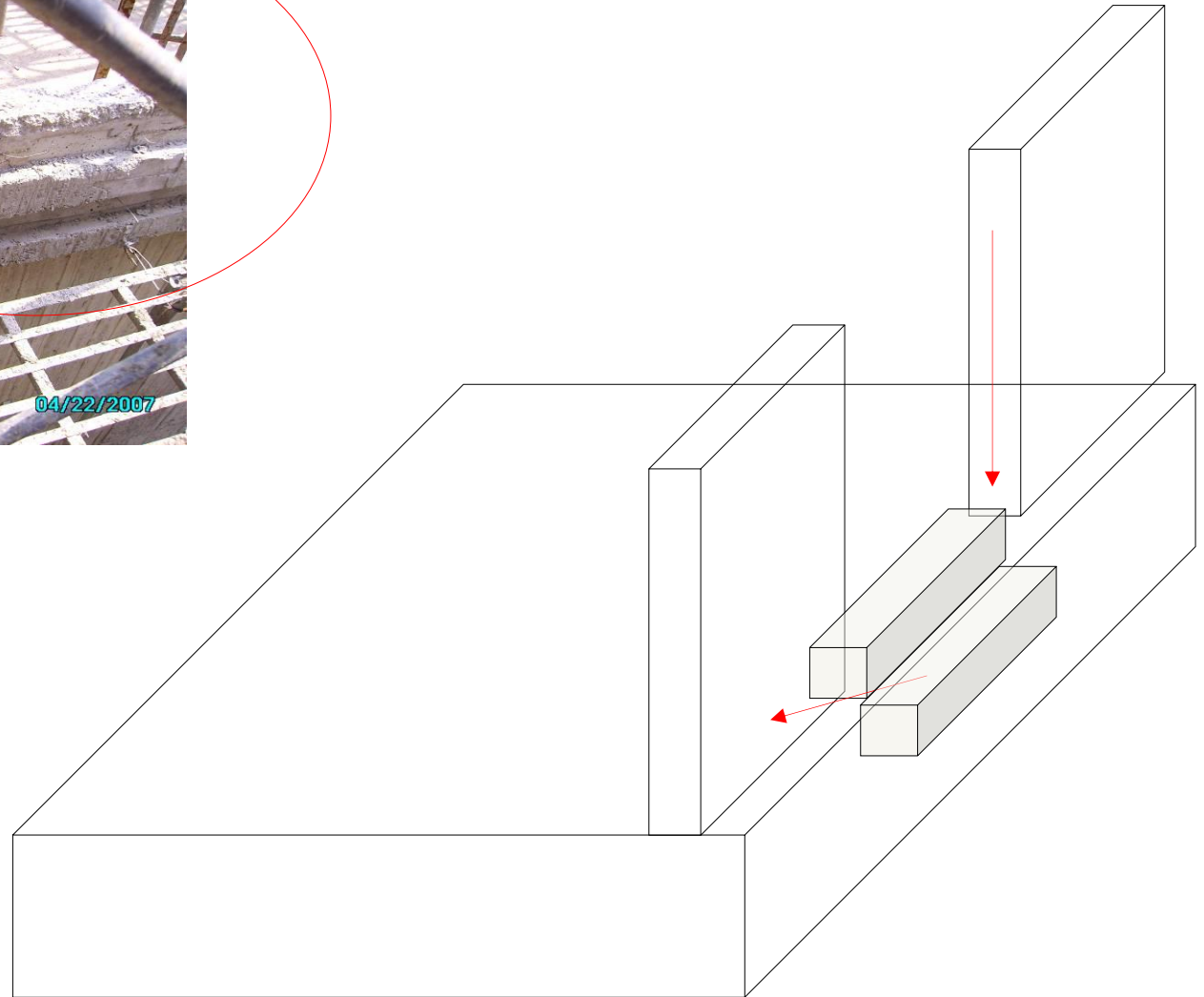

防水施工協調前置工種缺失改善

德瑞特化
工程有限公司

屋頂露台，斜式女兒牆銜接處
及斜式女兒牆需全面防水施工

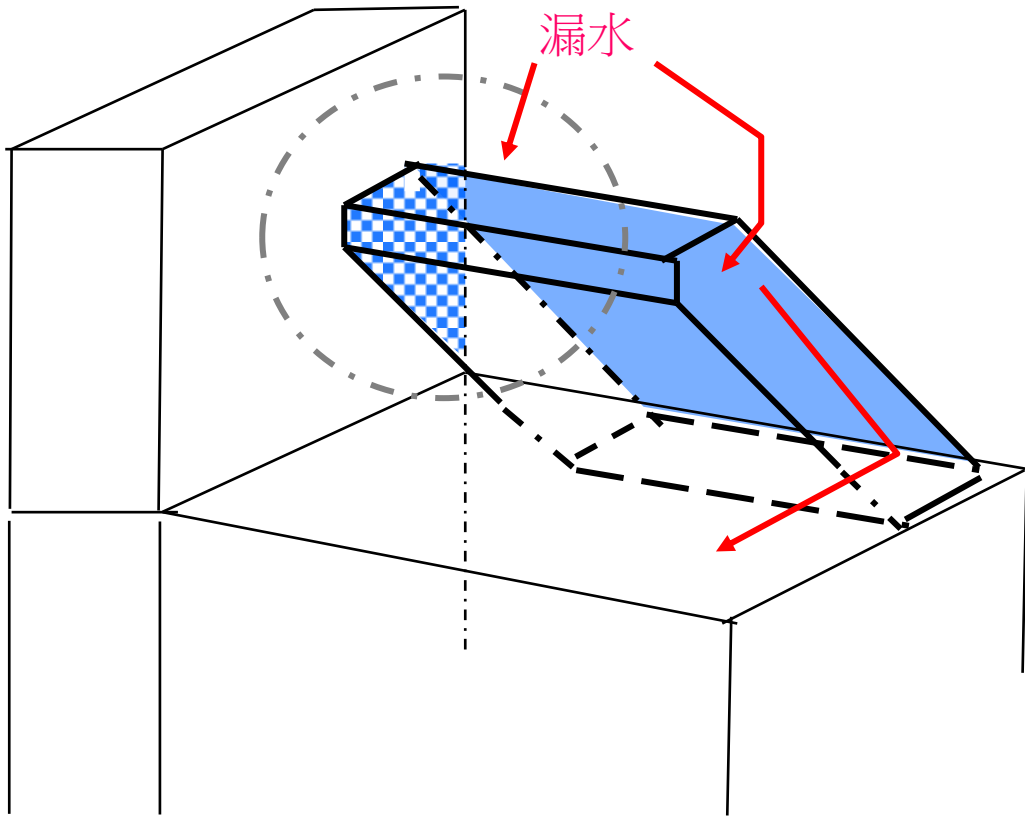

防水施工協調前置工種缺失改善

屋頂露台，造型外推女兒牆及打石面外牆，需全面防水施工。

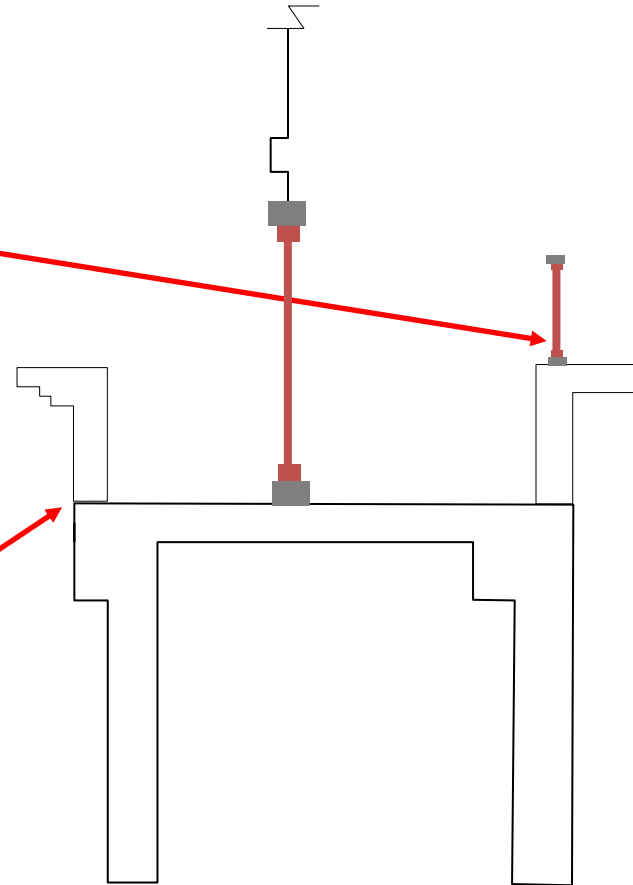

THE END